

Installation and Operating Instruction for B.E.G. - Occupancy detectors PD4-M-1C/-S-GH-SM

1. Mounting preparations

Work on the 230V mains supply may only be carried out by qualified professionals or by instructed persons under the direction and supervision of qualified skilled electrical personnel in accordance with electrical regulations.

Disconnect supply before installing!

The device is not suited for safe disconnection of the mains supply.

When in Master/Slave mode of operation, the Master-appliance must always be installed at the location where there is least daylight.

2a. Installation of the LUXOMAT® PD4-M-1C-GH-SM

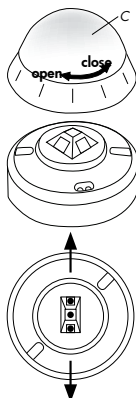

The detector must be installed on a solid and level surface. The circular cover ring must be removed prior to assembly. To do this, twist the lens (C) anti-clockwise through approximately 5° and lift off.

Having connected up the wires in accordance with regulations, secure the detector with 2 screws. After installation replace the lens and lock (turn clockwise). Mains to be connected.

ATTENTION: Install the unit in such a manner that both markings on the housing are positioned in the longitudinal axis of the area to be monitored (e.g. high-bay corridors)

2b. Range in dependence from the mounting height

Mounting height	Range (circular detection) T=17°C	
	Walking across	
2.00 m	r = 7.50 m	Ø = 15.00 m
2.50 m	r = 9.00 m	Ø = 18.00 m
3.00 m	r = 11.00 m	Ø = 22.00 m
3.50 m	r = 13.00 m	Ø = 26.00 m
4.00 m	r = 15.00 m	Ø = 30.00 m
4.50 m	r = 17.00 m	Ø = 34.00 m
5.00 m	r = 18.50 m	Ø = 37.00 m
6.00 m	r = 18.50 m	Ø = 37.00 m
7.00 m	r = 18.50 m	Ø = 37.00 m
8.00 m	r = 22.00 m	Ø = 44.00 m
9.00 m	r = 22.00 m	Ø = 44.00 m
10.00 m	r = 22.00 m	Ø = 44.00 m

r=radius / Ø=diameter

2c. Self test cycle

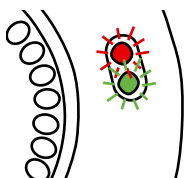

The product enters an initial 60-second self-test cycle, when the supply is first connected. The occupancy detector is ready for operation.

During the selftest cycle, the following settings can be made:

Light stop active: (A)

Light off active: (B)

(see point 7)

3. Putting into operation / Settings

Factory settings

The PD4-M-1C-GH is preset with time setting 5 min. and twilight switch 1000Lux.

Attention:

Changes to the settings can only be made by remote control IR-PD4-GH.

Pulse spacing PD-Slave

2 or 9 seconds can be set for the pause between 2 pulses sent to the master. The setting can be made with activated (●) or deactivated (○) LED indicator. For devices with a separate slave input, 2 sec. can be set.



5. PD4-M-1C-GH-SM - Dimensions

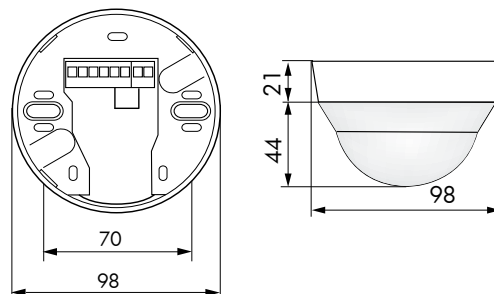

4. PD4-M-1C-GH: Settings carried out using remote control (optional)

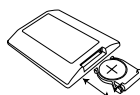

Remote control LUXOMAT® IR-PD4-GH

1. Check Battery:

Open battery compartment by pressing the plastic springs together and removing the battery-holder.

Settings for master with remote control

Settings for relay Channel 1:

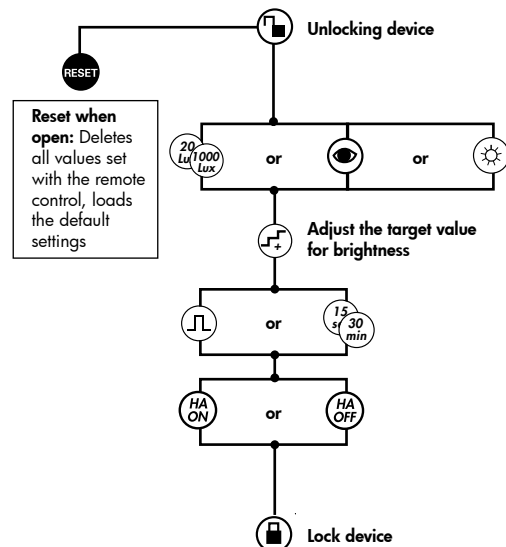

Option:



IR-PD4-GH



Wall bracket for remote control IR-PD4-GH



IR-PD-Mini

Explanation of button functions



Target value for brightness



Automatic reading in of the current light value as a new target light value



Sun button - specified twilight value



Daytime operation



Lag time



Pulse function, fully automatic mode active



Switch between fully automatic/semi-automatic mode



Semi-automatic mode active: Red + green LEDs flash 3x every 5 seconds



Adjust the target value for brightness



To reach the calculated target value, increase the light value by approx. 50 lux each time the button is pressed



Test mode when closed: exited automatically after 3 minutes



Test mode when open: not exited automatically



To deactivate: press reset



Reset when closed



The lighting relay is switched off, i.e. opened and the lag times are reset.



Light on/off when closed



(A) The light remains on/off until movements are detected in the detection area. After the last detected movement, the light remains off for the duration of the set lag time. (B) If the "Light stop" function was activated in the selftest cycle, the light is switched off for 5 seconds (red and green LEDs flash). The device then returns automatically to the selected operating mode (fully or semi-automatic mode).

6. Fully / Semi automatic mode

(for IR-PD functions see page 1)

Fully automatic operation

In this operating mode, the lighting switches automatically on and off for increased comfort, depending on presence and brightness.



Semiautomatic operation

(Semiautomatic can only be activated via the remote control!)

In this operating condition, in order to gain increased savings, the lighting is energized only after being manually switched on. Switch-off takes place automatically.



The semiautomatic mode basically behaves like the fully automatic one. However, the difference is that switching-on must always be carried out manually!

After automatic shutdown, motion detection is active for 15 seconds in semi-automatic mode.

As many (closer-contact) buttons as desired can be wired in parallel on the "S" button input (ON/OFF).

7. Manual Switching



(A) To switch the light on and off, press the button briefly. The light remains switched on or off for as long as people are detected plus the set lag time.

(B) If the "Light stop" function was activated in the selftest cycle, the light remains off for 5 seconds after shutdown (red and green LEDs flash). Then the automatic function is active again.

8. Range of Coverage

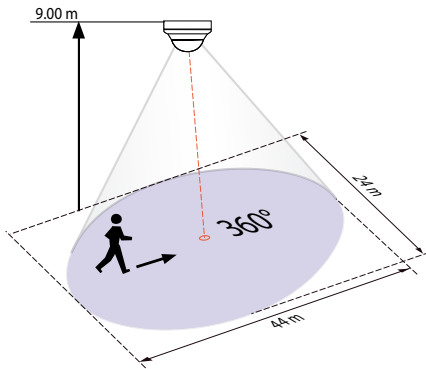

9. Technical data PD4-Master-1C-GH

Sensor and power supply in one

Power supply: 230V ~ ±10 %

Power consumption: < 1W

Ambient temperature: -25 °C to +50 °C

Degree of protection/class: IP20 / II

Settings: by remote control

Light values - IR-PD4-GH: 10 - 2000 Lux

Extension of the detection area:

with Slaves

Area of coverage: circular 360°

Range of coverage Ø H 10 m / T= 17 °C:

44 m tangential

Recommended height for mounting:

2 - 10 m

Light measurement: daylight and artificial light

Lux values: 10 - 2000 Lux

• **Relay/Channel 1 for light-connection**

Type of contact: NOC/with pretravel tungsten contact

Contact load: 2300 W cos φ=1 /

1150 VA cos φ=0,5, µ-Contact

Time-settings: 15 sec. - 30 min. / Test /

Impulse

Dimensions H x Ø [mm]: 98 x 65

Technical data PD4-Slave-GH

Power supply: 230V ~ ±10 %

Impulse output: Optocoupler max. 2W

Impulse duration: 2 sec. or 9 sec.

Dimensions: see above

CE Declaration of Conformity: The product complies with the low voltage recommendation 2006/95/EC and the EMV recommendation 2004/108/EC.

10. Wiring diagrams

Standard mode with master 1-channel occupancy detectors (NO) with R and S terminal

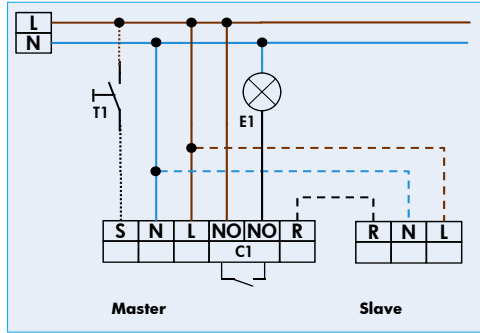

Optional

T1 = NO-button for semi automatic mode;
Extension of the detection area with Slave-devices

11. PD4-M-1C-GH - Connections

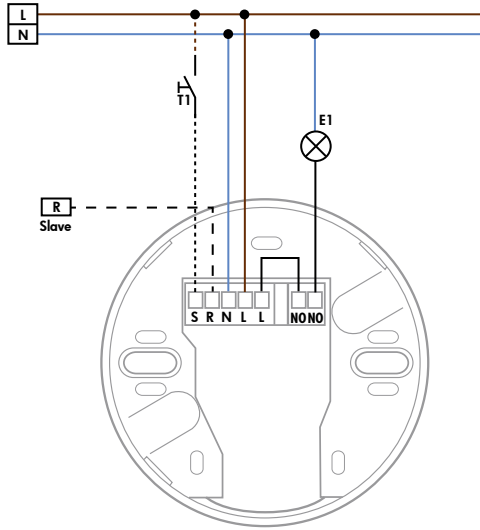

12. Article / Part nr. / Accessory

Type	SM
PD4-M-1C-GH (Master)	92245
PD4-S-GH (Slave)	92265

LUXOMAT® Remote control:

IR-PD4-GH (incl. wall bracket) 92215

IR-PD-Mini 92159

Accessory:

BSK Ball basket guard 92199

Wall bracket for remote control as replacement 92100

IP54 Socket 92161

13. LED-functional indicators, fault-finding

The functional indicators in the case of the LUXOMAT® PD4-M-1C-GH (red and green LED's)

Red and green LEDs for display of the selftest cycle (For 60 seconds after the power is switched on)

Red and green LEDs flash 1x per second

EEPROM/ memory empty

Red and green LEDs flash 2x per second

EEPROM/ memory written

Red LED as status display

Red LED flashes irregularly

Movements are detected in the detection area

Red LED flashes 2x per second

Detector detects brightness, light off

(depending on the operating mode)

Red LED does not light up

Detector detects darkness, light on

(depending on the operating mode)

Red LED as acknowledgement for commands from the remote control

Red LED lights up for 1 second

Valid signal received

Red LED lights up for 0.25 seconds

Command not accepted, detector is locked

Red LED flashes extremely quickly

Command not accepted, for example if twilight value is too light or too dark

Red and green LED as acknowledgement for commands from the remote control

Red and green LEDs flash 3x briefly every 5 seconds

Indicates semi-automatic mode

Red and green LEDs light up alternately

Determining the light value for automatic shutdown with sufficient daylight. (This is only indicated with a set lag time of 30 minutes.)