



X-S8-F	Ultrasonic Fill Level Measurement System		Product Group 10
EIB/KNX, Indoor / Outdoor, IP65	Document: 3700_ex_X-S8-F.pdf		Article No.
	<p>Ultrasonic sensor / controller for monitoring and control of fill levels in cisterns, reservoirs, pools or tanks with KNX coupling unit.</p> <p>The ultrasonic level sensor system LevelJET from ProJET evaluates the levels in reservoirs of many construction types. Minimal and maximal levels can be set on site. The bus coupling unit enables to use the values in the KNX-Bus.</p> <p>Use case: Monitoring and control of liquid levels in cisterns and tanks.</p> <p>Additional supply of 9 .. 12 VDC / 35mA necessary . Wall power supply included in delivery.</p> <p>Two housings are available as shown below</p>		
	<p>SK01-S8-F -ST</p> <p>SK01-S8-F -HR-6</p>	<p>SK01 plastic housing 72 x 64 x 40 mm IP65 Mounted with 2 screws onto the wall.</p> <p>Measuring range: 0,15 .. 2,5 m</p> <p>Measuring range: 0,75 .. 6 m</p>	<p>30807001</p> <p>30807011</p>
	<p>REG-S8-F -ST</p> <p>REG-S8-F -HR-6</p>	<p>DIN Rail mounted housing 2 units width (35 mm) IP20</p> <p>Measuring range: 0,15 .. 2,5 m</p> <p>Measuring range: 0,75 .. 6 m</p>	<p>30807002</p> <p>30807012</p>

7.1 Application Description	2	7.5 Product Page	20
7.2 KNX Parameter	2	7.6 Technical Data	21
7.3 KNX Objects	17	7.7 Startup	23
7.4 Notes	19	7.8 Assembly	23
Imprint			

Application Description

X-S8-F Ultrasonic Fill Level

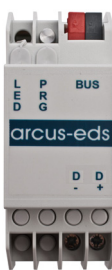
7.1 Application Description

Operating Principles and Areas of Application

The production series S8 uses sensors and controllers for a number of physical and chemical measurements for indoor and outdoor areas.

The measurement system **X-S8-F** uses the ultrasound sensor LevelJET from the manufacturer ProjET to measure the filling levels of water cisterns or tanks of different designs.

The measurement of the filling levels is based upon a runtime measurement of the ultrasound impulses emitted by the sensor, as they are reflected by the medium and then registered by the sensor.

When the controller is used, there are 2-point controllers with a switched or pulsed 1-bit output available.

KNX sensors are set up using the ETS (KNX Tool Software) with the associated application program.

The device is delivered unprogrammed.

All functions are parameterized and programmed by ETS.

The controller can be switched on or off by activation or locking via the KNX bus.

Functions

Ultrasonic fill level with

- Two position controller with switch and pulse 1-bit output
- Measured Value can be periodically displayed or when value changes
- Überwachung in Liter oder Volumen
- Adjustable release and lock with both controllers (parameterized)
- Threshold alarm for upper and lower thresholds
- Auxiliary quantity of set value or threshold via the bus

7.2 KNX Parameter

7.2.1 General Settings	3		
7.2.2 Volume Fill Level	4	7.2.3 Controller Volume Fill Level	5
7.2.4 Level	7	7.2.5 Controller Level	8
7.2.6 Distance	10	7.2.7 Controller Distance	11
7.2.8 Volume Fill Level in %	13	7.2.9 Controller Volume Fill Level in %	14
7.2.10 Output 1	15	7.2.11 Output 2	15

7.2.1 General Settings

General Settings - X-S8-F

Parameter	Setting	Description
Measured value send cycle period	1 .. 120 minutes	The transmission period of the measurement values that are to be sent cyclically. In the parameter set „Measured value x“ you can determine if the measurement values are sent periodically.
Actuating value send cycle period (Seconds)	10 .. 250	The transmission period of the correcting variables of the controller that are to be sent cyclically. In the parameter set „Controller x“ you can determine if the measurement values are sent periodically.
Use clock timer	<ul style="list-style-type: none"> • No • Yes 	When the timer is used, two additional parameters (timer from / to) and the objects 58 „device time“ and 59 „device date“ are available.
Timer from Timer until	0 .. 24 hour	The controller output can be locked depending on the time of day. The time in which the controller is unlocked must be entered here. In the parameter set „Controller x“ you can determine if the timer function is to be used for a specified controller.

7.2.2 Volume Fill Level

General settings	Volume fill level
Volume fill level	
Controller volume fill level	
Level	Measured value send periodical: no
Controller level	Measured value send by change: no
Distance	Unit volume fill level: Liter (l)
Controller distance	Type datapoint: 2byte unsigned
Volume fill level in %	Auxiliary object is: Setpoint
Controller volume fill level in %	Auxiliary value store by change: no
Output 1	Lower limit: 1
Output 2	Unit lower limit: Liter (l)
	Upper limit: 1
	Unit upper limit: Liter (l)
	Differential gaps send/limits: 1
	Unit differential gaps send/limits: Liter (l)

Volume Fill Level - X-S8-F

Parameter	Setting	Description
Measured value send periodical	<ul style="list-style-type: none"> No Yes 	The transmission period can be parameterized in the parameter set „General Settings“.
Measured value send by change	<ul style="list-style-type: none"> No Yes 	The necessary change can be set in the parameter „Differential gap send / limits“.
Unit volume fill level	<ul style="list-style-type: none"> Liter (l) Cubic metre (m³) 	Unit specification of the volume to be measured
Type datapoint	<ul style="list-style-type: none"> 2-Byte unsigned 4-Byte unsigned 2-Byte float 4-Byte float 	Measured Data Output and Auxiliary Data are defined concurrently.
Auxiliary object is	<ul style="list-style-type: none"> Setpoint Upper limit Lower limit 	Every controller has an auxiliary object which can control either the set point of the controller or the limit values.
Auxiliary value store by change	<ul style="list-style-type: none"> No Yes 	When the auxiliary data is changed the new value is carried over to EEPROM and saved in case of a bus voltage breakdown. This should be used only when the data is not frequently changed as EEPROM has only a limited memory cycle.
Lower limit	-32000 .. 32000	If the measured value corresponds with the preset value, the object 5 „Output, Lower Limit volume fill level“ will be set.

Application Description
X-S8-F Ultrasonic Fill Level

Volume Fill Level - X-S8-F (continue)

Parameter	Setting	Description
Unit Lower limit	<ul style="list-style-type: none"> Liter (l) Cubic metre (m³) 	Unit specification for the lower limit.
Upper limit	-32000 .. 32000	If the measured value corresponds with the preset value, the object 4 „Output, Upper Limit volume fill level“ will be set.
Unit Upper limit	<ul style="list-style-type: none"> Liter (l) Kubikmeter (m³) 	Unit specification for the upper limit.
Differential gap send / limits	-32000 .. 32000	In order to limit the busload when the values change and to avoid multiple switching within the range of the limits, an appropriate hysteresis value should be applied.
Unit Differential gap send / limits	<ul style="list-style-type: none"> Liter (l) Cubic metre (m³) 	Unit specification for the „Differential gap send / limits“.



7.2.3 Controller Volume Fill Level

General settings

Volume fill level

Controller volume fill level

Level

Controller level

Distance

Controller distance

Volume fill level in %

Controller volume fill level in %

Output 1

Output 2

Controller volume fill level

Locking object	locked if 1
Actuating variable at rising actual value	increasing
Controller	Two-level controller
Setpoint	1
Unit Setpoint	Liter (l)
Differential gap Controller	1
Unit differential gap Controller	Liter (l)
Actuating variable send periodical	no
use clock timer	no

Controller Volume Fill Level - X-S8-F

Parameter	Setting	Description
Locking object	<ul style="list-style-type: none"> locked if 1 locked if 0 	When using the Locking object 7 „Input, enable / lock volume fill level“ the controller output is deactivated. The lock function can be set up for „release“ or „lock“.
Actuating value by ascending actual value	<ul style="list-style-type: none"> increasing decreasing 	The actuating direction of the controller can be adapted to the characteristics of the controlled system.

Application Description
 X-S8-F Ultrasonic Fill Level

Controller Volume Fill Level - X-S8-F (continue)

Parameter	Setting	Description
Controller	<ul style="list-style-type: none"> • Two-Position Controller • Two-Position Controller Pulsed 	The different controller types and the corresponding parameters are described in chapter 7.4 Notes .
Setpoint	-32000 .. 32000	Setpoint setting
Unit Setpoint	<ul style="list-style-type: none"> • Liter (l) • Cubic metre (m³) 	Unit specification for the Setpoint.
Differential gap Cotroller	-32000 .. 32000	Specification for the (hysteresis). see chapter 7.4 Notes - Two-Positon Control
Unit Differential gap Cotroller	<ul style="list-style-type: none"> • Liter (l) • Cubic metre (m³) 	Unit specification for the „Differential gap Cotroller“ (hysteresis).
Actuating value send cyclical	<ul style="list-style-type: none"> • No • Yes 	The cycle period is set in „General Settings“.
Duty cycle in %	0 .. 50	duty cycle = pulse duration / cycle duration x 100 see chapter 7.4 Notes - Two-Positon Control with Pulsed Output
Cycle duration in seconds	0 .. 65535	Total time of On and Off state.
Use clock timer	<ul style="list-style-type: none"> • No • Yes 	The use of the clock timer can be enable / disable for each channel separately.

7.2.4 Level

General settings	Level
Volume fill level	
Controller volume fill level	
Level	Measured value send periodical: no
Controller level	Measured value send by change: no
Distance	Level unit: m
Controller distance	Type datapoint: 2byte unsigned
Volume fill level in %	Auxiliary object is: Setpoint
Controller volume fill level in %	Auxiliary value store by change: no
Output 1	Lower limit: 1
Output 2	Unit lower limit: m
	Upper limit: 1
	Unit upper limit: m
	Differential gaps send/limits: 1
	Unit differential gaps send/limits: m

Level - X-S8-F

Parameter	Setting	Description
Measured value send cyclical	<ul style="list-style-type: none"> No Yes 	The transmission period can be parameterized in the parameter set „General Settings“.
Measured value send by change	<ul style="list-style-type: none"> No Yes 	The necessary change can be set in the parameter „Differential gap send / limits“ and „Unit Differential gap send / limits“
Level unit	<ul style="list-style-type: none"> m dm cm mm 	Unit specification for the level.
Type datapoint	<ul style="list-style-type: none"> 2-Byte unsigned 4-Byte unsigned 2-Byte float 4-Byte float 	Measured Data Output and Auxiliary Data are defined concurrently.
Auxiliary object is	<ul style="list-style-type: none"> Setpoint Upper limit Lower limit 	Every controller has an auxiliary object which can control either the set point of the controller or the limit values.
Auxiliary value store by change	<ul style="list-style-type: none"> No Yes 	When the auxiliary data is changed the new value is carried over to EEPROM and saved in case of a bus voltage breakdown. This should be used only when the data is not frequently changed as EEPROM has only a limited memory cycle.

Application Description

X-S8-F Ultrasonic Fill Level

Level - X-S8-F (continue)

Parameter	Setting	Description
Lower limit	-32000 .. 32000	If the measured value corresponds with the preset value, the object 12 „Output, Lower Limit level“ will be set.
Unit Lower limit	<ul style="list-style-type: none"> • m • dm • cm • mm 	Unit specification for the lower limit.
Upper limit	-32000 .. 32000	If the measured value corresponds with the preset value, the object 11 „Output, Upper Limit level“ will be set.
Unit Upper limit	<ul style="list-style-type: none"> • m • dm • cm • mm 	Unit specification for the upper limit.
Differential gap send / limits	-32000 .. 32000	In order to limit the busload when the values change and to avoid multiple switching within the range of the limits, an appropriate hysteresis value should be applied.
Unit Differential gap send / limits	<ul style="list-style-type: none"> • m • dm • cm • mm 	Unit specification for the „Differential gap send / limits“.

7.2.5 Controller Level

General settings

Volume fill level

Controller volume fill level

Level

Controller level

Distance

Controller distance

Volume fill level in %

Controller volume fill level in %

Output 1

Output 2

Controller level

Locking object locked if 1

Actuating variable at rising actual value increasing

Controller Two-level controller

Setpoint 1

Unit setpoint m

Differential gap Controller 1

Unit differential gap Controller m

Actuating variable send periodical no

use clock timer no

Application Description

X-S8-F Ultrasonic Fill Level

Controller Level - X-S8-F

Parameter	Setting	Description
Locking object	<ul style="list-style-type: none"> • locked if 1 • locked if 0 	When using the Locking object 14 „Input, enable / lock level“ the controller output is deactivated. The lock function can be set up for „release“ or „lock“.
Actuating value by ascending actual value	<ul style="list-style-type: none"> • increasing • decreasing 	The actuating direction of the controller can be adapted to the characteristics of the controlled system.
Controller	<ul style="list-style-type: none"> • Two-Position Controller • Two-Position Controller Pulsed 	The different controller types and the corresponding parameters are described in chapter 7.4 Notes
Setpoint	-32000 .. 32000	Setpoint setting
Unit Setpoint	<ul style="list-style-type: none"> • m • dm • cm • mm 	Unit specification for the Setpoint.
Differential gap controller	-32000 .. 32000	Specification for the (hysteresis). see chapter 7.4 Notes - Two-Positon Control
Unit Differential gap controller	<ul style="list-style-type: none"> • m • dm • cm • mm 	Unit specification for the „Differential gap Cotroller“ (hysteresis).
Actuating value send cyclical	<ul style="list-style-type: none"> • No • Yes 	The cycle period is set in „General Settings“.
Duty cycle in %	0 .. 50	duty cycle = pulse duration / cycle duration x 100 see chapter 7.4 Notes - Two-Positon Control with Pulsed Output
Cycle duration in seconds	0 .. 65535	Total time of On and Off state.
Use clock timer	<ul style="list-style-type: none"> • No • Yes 	The use of the clock timer can be enable / disable for each channel separately.

7.2.6 Distance

General settings	Distance
Volume fill level	Measured value send periodical <input type="text" value="no"/>
Controller volume fill level	Measured value send by change <input type="text" value="no"/>
Level	Distance unit <input type="text" value="m"/>
Controller level	Type datapoint <input type="text" value="2byte unsigned"/>
Distance	Auxiliary object is <input type="text" value="Setpoint"/>
Controller distance	Auxiliary value store by change <input type="text" value="no"/>
Volume fill level in %	Lower limit <input type="text" value="1"/>
Controller volume fill level in %	Unit lower limit <input type="text" value="m"/>
Output 1	Upper limit <input type="text" value="1"/>
Output 2	Unit upper limit <input type="text" value="m"/>
	Differential gaps send/limits <input type="text" value="1"/>
	Unit Differential gaps send/limits <input type="text" value="m"/>

Distance - X-S8-F

Parameter	Setting	Description
Measured value send cyclical	<ul style="list-style-type: none"> No Yes 	The transmission period can be parameterized in the parameter set „General Settings“.
Measured value send by change	<ul style="list-style-type: none"> No Yes 	The necessary change can be set in the parameter „Differential gap send / limits“.
Distance unit	<ul style="list-style-type: none"> m dm cm mm 	Unit specification of the distance to be measured.
Type datapoint	<ul style="list-style-type: none"> 2-Byte unsigned 4-Byte unsigned 2-Byte float 4-Byte float 	Measured Data Output and Auxiliary Data are defined concurrently.
Auxiliary object is	<ul style="list-style-type: none"> Setpoint Upper limit Lower limit 	Every controller has an auxiliary object which can control either the set point of the controller or the limit values.
Auxiliary value store by change	<ul style="list-style-type: none"> No Yes 	When the auxiliary data is changed the new value is carried over to EEPROM and saved in case of a bus voltage breakdown. This should be used only when the data is not frequently changed as EEPROM has only a limited memory cycle.
Lower limit	-32000 .. 32000	If the measured value corresponds with the preset value, the object 19 „Output, Lower Limit distance“ will be set.

Distance - X-S8-F (continue)

Parameter	Setting	Description
Unit Lower limit	<ul style="list-style-type: none"> • m • dm • cm • mm 	Unit specification for the lower limit.
Upper limit	-32000 .. 32000	If the measured value corresponds with the preset value, the object 18 „Output, Upper Limit distance“ will be set.
Unit Upper limit	<ul style="list-style-type: none"> • m • dm • cm • mm 	Unit specification for the upper limit.
Differential gap send / limits	-32000 .. 32000	In order to limit the busload when the values change and to avoid multiple switching within the range of the limits, an appropriate hysteresis value should be applied.
Unit Differential gap send / limits	<ul style="list-style-type: none"> • m • dm • cm • mm 	Unit specification for the „Differential gap send / limits“.



7.2.7 Controller Distance

General settings

Volume fill level

Controller volume fill level

Level

Controller level

Distance

Controller distance

Volume fill level in %

Controller volume fill level in %

Output 1

Output 2

Controller distance

Locking object	locked if 1
Actuating variable at rising actual value	increasing
Controller	Two-level controller
Setpoint	1
Unit Setpoint	m
Differential gap Controller	1
Unit differential gap Controller	m
Actuating variable send periodical	no
use clock timer	no

Application Description
 X-S8-F Ultrasonic Fill Level

Controller Distance - X-S8-F

Parameter	Setting	Description
Locking object	<ul style="list-style-type: none"> • locked if 1 • locked if 0 	When using the Locking object 14 „Input, enable / lock level“ the controller output is deactivated. The lock function can be set up for „release“ or „lock“.
Actuating value by ascending actual value	<ul style="list-style-type: none"> • increasing • decreasing 	The actuating direction of the controller can be adapted to the characteristics of the controlled system.
Controller	<ul style="list-style-type: none"> • Two-Position Controller • Two-Position Controller Pulsed 	The different controller types and the corresponding parameters are described in chapter 7.4 Notes
Setpoint	-32000 .. 32000	Setpoint setting
Unit Setpoint	<ul style="list-style-type: none"> • m • dm • cm • mm 	Unit specification for the Setpoint.
Differential gap controller	-32000 .. 32000	Specification for the (hysteresis). see chapter 7.4 Notes - Two-Positon Control
Unit Differential gap controller	<ul style="list-style-type: none"> • m • dm • cm • mm 	Unit specification for the „Differential gap Cotroller“ (hysteresis).
Actuating value send cyclical	<ul style="list-style-type: none"> • No • Yes 	The cycle period is set in „General Settings“.
Duty cycle in %	0 .. 50	duty cycle = pulse duration / cycle duration x 100 see chapter 7.4 Notes - Two-Positon Control with Pulsed Output
Cycle duration in seconds	0 .. 65535	Total time of On and Off state.
Use clock timer	<ul style="list-style-type: none"> • No • Yes 	The use of the clock timer can be enable / disable for each channel separately.

7.2.8 Volume Fill Level in %

Volume fill level in %	
General settings	
Volume fill level	
Controller volume fill level	
Level	
Controller level	
Distance	
Controller distance	
Volume fill level in %	
Controller volume fill level in %	
Output 1	
Output 2	
Measured value send periodical	no
Measured value send by change	no
Range	0 to 100 % (DP 5.001)
Auxiliary object is	Setpoint
Measured value send by change	no
Lower limit	15
Upper limit	90
Differential gaps send/limits	1

Volume Fill Level in % - X-S8-F

Parameter	Setting	Description
Measured value send cyclical	<ul style="list-style-type: none"> No Yes 	The transmission period can be parameterized in the parameter set „General Settings“.
Measured value send by change	<ul style="list-style-type: none"> No Yes 	The necessary change can be set in the parameter „Differential gap send / limits“
Range	• 0 bis 255 % (DP 5.004)	The setting 0 .. 255 % means that the range of values 0 .. 100 can be set in 255 steps. 1 step equals 0.392 % of the final value.
	• 0 bis 100 % (DP 5.001)	The setting 0 .. 100 % means that the range of values 0 .. 100 can be set in 100 steps.
Auxiliary object is	<ul style="list-style-type: none"> Setpoint Upper limit Lower limit 	Every controller has an auxiliary object which can control either the set point of the controller or the limit values.
Auxiliary value store by change	<ul style="list-style-type: none"> No Yes 	When the auxiliary data is changed the new value is carried over to EEPROM and saved in case of a bus voltage breakdown. This should be used only when the data is not frequently changed as EEPROM has only a limited memory cycle.
Lower limit	0 .. 255	If the measured value corresponds with the preset value, the object 26 „Output, Lower Limit fill level“ will be set. Please pay attention to the preset in the parameter „Range“.
Upper limit	0 .. 255	If the measured value corresponds with the preset value, the object 25 „Output, Lower Limit fill level“ will be set. Please pay attention to the preset in the parameter „Range“.

Application Description
X-S8-F Ultrasonic Fill Level

Volume Fill Level in % - X-S8-F (continue)

Parameter	Setting	Description
Differential gap send / limits	-32000 .. 32000	In order to limit the busload when the values change and to avoid multiple switching within the range of the limits, an appropriate hysteresis value should be applied.

7.2.9 Controller Volume Fill Level in %

Controller Volume Fill Level in % - X-S8-F

Parameter	Setting	Description
Locking object	<ul style="list-style-type: none"> locked if 1 locked if 0 	When using the Locking object 28 „Input, enable / lock volume fill level %“ the controller output is deactivated. The lock function can be set up for „release“ or „lock“.
Actuating value by ascending actual value	<ul style="list-style-type: none"> increasing decreasing 	The actuating direction of the controller can be adapted to the characteristics of the controlled system.
Controller	<ul style="list-style-type: none"> Two-Position Controller Two-Position Controller Pulsed 	The different controller types and the corresponding parameters are described in chapter 7.4 Notes
Setpoint	-32000 .. 32000	Setpoint setting
Differential gap controller	-32000 .. 32000	Specification for the (hysteresis). see chapter 7.4 Notes - Two-Positon Control
Actuating value send cyclical	<ul style="list-style-type: none"> No Yes 	The cycle period is set in „General Settings“.

Controller Volume Fill Level in % - X-S8-F (continue)

Parameter	Setting	Description
Duty cycle in %	0 .. 50	duty cycle = pulse duration / cycle duration x 100 see chapter 7.4 Notes - Two-Position Control with Pulsed Output
Cycle duration in seconds	0 .. 65535	Total time of On and Off state.
Use clock timer	<ul style="list-style-type: none"> • No • Yes 	The use of the clock timer can be enable / disable for each channel separately.



7.2.10 Output 1

General settings

Volume fill level

Controller volume fill level

Level

Controller level

Distance

Controller distance

Volume fill level in %

Controller volume fill level in %

Output 1

Output 2

Output 1

Measured value send periodical no ▾

Measured value send by change no ▾

Output 1 - X-S8-F

Parameter	Setting	Description
Measured value send cyclical	<ul style="list-style-type: none"> • No • Yes 	The transmission period can be parameterized in the parameter set „General Settings“.
Measured value send by change	<ul style="list-style-type: none"> • No • Yes 	A change of the switching input 1 will (not) be transmitted.

7.2.11 Output 2

General settings

Volume fill level

Controller volume fill level

Level

Controller level

Distance

Controller distance

Volume fill level in %

Controller volume fill level in %

Output 1

Output 2

Output 2

Measured value send periodical no ▾

Measured value send by change no ▾

use clock timer no ▾

X-S8-F Output 2

Parameter	Setting	Description
Measured value send cyclical	<ul style="list-style-type: none">• No• Yes	The transmission period can be parameterized in the parameter set „General Settings“.
Measured value send by change	<ul style="list-style-type: none">• No• Yes	A change of the switching input 2 will (not) be transmitted.
Use clock timer	<ul style="list-style-type: none">• No• Yes	The use of the clock timer can be enable / disable for each channel separately.

7.3 KNX Objects

Objects - X-S8-F

No.	Label	Data Point Type	Function
2	Output, measured volume fill level	DPT 4 Byte	Measured value
3	Input, auxiliary volume fill level	DPT 4 Byte	Auxiliary value
4	Output, upper limit volume fill level	DPT 1.002 Bool 1 Bit	Limit
5	Output, lower limit volume fill level	DPT 1.002 Bool 1 Bit	Limit
6	Output, controller volume fill level	DPT	Actuating value
7	Input, enable/lock volume fill level	DPT 1.001 Switch 1 Bit	Enable/lock
8	Output, status volume fill level	DPT 1 Byte	Channel status
9	Output, measured level	DPT	Measured value
10	Input, auxiliary object level	DPT	Auxiliary value
11	Output, upper limit level	DPT 1.002 Bool 1 Bit	Limit
12	Output, lower limit level	DPT 1.002 Bool 1 Bit	Limit
13	Output, controller level	DPT	Actuating value
14	Input, enable/lock level	DPT 1.001 Switch 1 Bit	Enable/lock
15	Output, status level	DPT 1 Byte	Channel status
16	Output, measured distance	DPT	Measured value
17	Input, auxiliary object distance	DPT	Auxiliary value
18	Output, upper limit distance	DPT 1.002 Bool 1 Bit	Limit
19	Output, lower limit distance	DPT 1.002 Bool 1 Bit	Limit
20	Output, controller distance	DPT	Actuating value
21	Input, enable/lock distance	DPT 1.001 Switch 1 Bit	Enable/lock
22	Output, status distance	DPT 1 Byte	Channel status
23	Output, measured volume fill level %	DPT 4 Byte	Measured value
24	Input, auxiliary object volume fill level %	DPT 4 Byte	Auxiliary value
25	Output, upper limit volume fill level %	DPT 1.002 Bool 1 Bit	Limit
26	Output, lower limit volume fill level %	DPT 1.002 Bool 1 Bit	Limit
27	Output, controller volume fill level %	DPT	Actuating value

Objects - X-S8-F (continue)

No.	Label	Data Point Type	Function
28	Input, enable/lock volume fill level %	DPT 1.001 Switch 1 Bit	Enable/lock
29	Output, status volume fill level %	DPT 1 Byte	Channel status
30	Output, measured output 1	DPT 1.001 Switch 1 Bit	Measured value
37	Output, measured output 2	DPT 1.001 Switch 1 Bit	Measured value
58	Equipment time	DPT 10.001 Time of day 3 Byte	Time
59	Equipment date	DPT 11.001 day of month 3 Byte	Date

X-S8-F Object Description

No.	Label	Description																												
8	Output, status volume fill level	The values of the individual bits are added and transmitted to the bus. The status functions monitor the controller status for purposes of reporting and troubleshooting.																												
15	Output, status level																													
22	Output, status distance	<table border="1"> <thead> <tr> <th>Status:</th> <th>Bit-No.</th> <th>Hexadecimal</th> <th>Decimal</th> </tr> </thead> <tbody> <tr> <td>upper limit too large</td> <td>0</td> <td>0x01</td> <td>1</td> </tr> <tr> <td>lower limit underrun</td> <td>1</td> <td>0x02</td> <td>2</td> </tr> <tr> <td>setpoint not equal to zero</td> <td>2</td> <td>0x04</td> <td>4</td> </tr> <tr> <td>lock activ</td> <td>4</td> <td>0x10</td> <td>16</td> </tr> <tr> <td>auxiliary is stored</td> <td>5</td> <td>0x20</td> <td>32</td> </tr> <tr> <td>timer activ</td> <td>6</td> <td>0x40</td> <td>64</td> </tr> </tbody> </table>	Status:	Bit-No.	Hexadecimal	Decimal	upper limit too large	0	0x01	1	lower limit underrun	1	0x02	2	setpoint not equal to zero	2	0x04	4	lock activ	4	0x10	16	auxiliary is stored	5	0x20	32	timer activ	6	0x40	64
Status:	Bit-No.		Hexadecimal	Decimal																										
upper limit too large	0	0x01	1																											
lower limit underrun	1	0x02	2																											
setpoint not equal to zero	2	0x04	4																											
lock activ	4	0x10	16																											
auxiliary is stored	5	0x20	32																											
timer activ	6	0x40	64																											
29	Output, status volume fill level %																													

7.4 Notes

Controller models available are the PI controller or a two-position controller. Both controllers are equipped with pulsed output. The pulsed two-position controller works with constant duty cycle, which like the cycle duration is parameterized. The duty cycle of the pulsed PI controller is variable and depends on the control variable (pulse-width modulation).

Two-Position Control

Two-position control is a very simple way of controlling.

Once the actual value (\pm half the switching difference) exceeds or falls below the set point a switch-on or switch-off command is sent to the bus.

Set the differential gap large enough to keep bus load to a minimum and configure the differential gap small enough to avoid extreme actual value fluctuations.

The two-position controller is parameterized using the set point and the switching threshold.

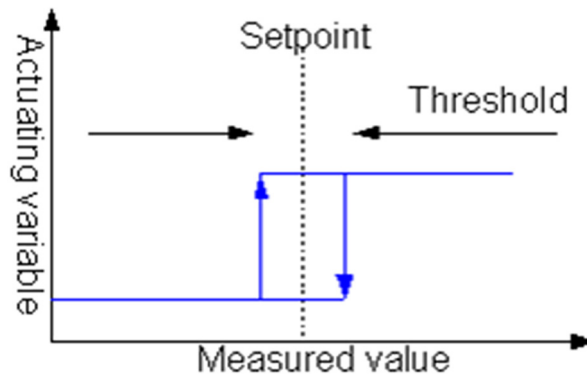

Two-Position Control with Pulsed Output

The controller works analogous to the two-position controller.

The actuating variable emits pulses with fixed duty cycle.

When the control variable reaches 40% in a cycle time of 10 minutes it will repeatedly turned on for 4 minutes and turned off for 6 minutes.

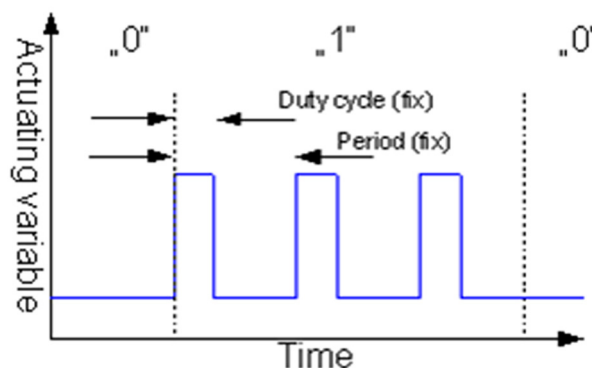

7.5 Product Page

The ultrasonic level sensor system LevelJET from ProJET evaluates the levels in reservoirs of many construction types. Minimal and maximal levels can be set on site. The bus coupling unit enables to use the values in the KNX-Bus.

The device has an integrated KNX bus coupler and required, depending on the measurement electronics and configure, an additional voltage between 9 .. 12 VDC / 35mA.

In the application software a separate controller (2-position or 2-position with continuous or pulsed output) is available for every channel.

Other functions include maximum and minimum thresholds and a help key where the set point and thresholds can be switched.

The sensor is configured with ETS (KNX Tool Software) and the application program. Controlling functions such as signal threshold and diverse adjustments are set using ETS (KNX Tool Software).

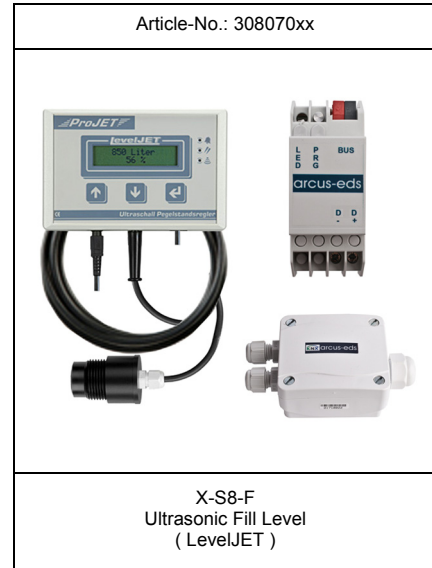

Areas of Application

- Surveillance and control of fill levels in water cisterns or tanks.
- Different container designs can be parameterized

<p>Applicable Sensors: Ultrasonic LevelJET</p> <p>Meas. Range X-S8-F-ST: 0,15 .. 2,5 m Meas. Range X-S8-F-HR-6: 0,75 .. 6 m Resolution: 1 mm</p> <p>Operating Voltage: 21 .. 32 VDC Power Consumption: approx. 240mW (bei 24VDC) Auxiliary Voltage: 9 .. 12 VDC / 35mA</p> <p>Operating Temperature: -20 .. + 55 °C Storage Temperature: -20 .. + 85 °C</p> <p>Ambient temperature Ultrasonic LevelJET according to manufacturer's specifications</p> <p>Orientation of Ultrasonic -Sensor according to manufacturer's specifications</p> <p>Protection Class Casing SK01: IP65 Protection Class Casing REG: IP20 Protection Class Ultrasonic-Sensor: IP65 Protection Class Casing LevelJET: none</p>	
---	--

7.6 Technical Data

Technical Data - X-S8-F

Measured Data	Volume fill level in liter or cubic meters Level Distance Volume fill level in %
Sending Options	no sending, cyclical sending when change occurs
Parameter	Periodic sending with variable cycle duration, sending when change occurs with variable hysteresis
Objekttyp T1 .. T8	2-Byte unsigned, 4-Byte unsigned, 2-Byte float, 4-Byte float
Controller Modi	Two-Position controller Two-Position controller Pulsed
Parameter Two-Position controller	Setpoint, differential gap, controller mode
Parameter Two-Position controller Pulsed	Setpoint, differential gap, controller mode , cycle duration, duty cycle
Lock Function	All controller parameterizable as enable or lock
Controller Variables Output	depends on Controller Modi 1-Byte unsigned, 1-Bit Switch
Setpoint value send cyclical	None or 10-250 seconds, parameterizable
Limits	Lower limit, Upper limit
Auxiliary value	Setpoint, Upper limit or Lower limit
Bus power failure	Saving changed auxiliary quantities, parameterizable
Measured value shift	none
Ambient Temperature Electronic Measuring Equipment Casing	Operation: -20 .. +55 °C Storage: -20 .. +85 °C
Ambient Humidity	0 .. 95% rH not condensating
Measuring range	0,15 .. 2,5 m 0,75 .. 6 m
Resolution fill level	± 1 mm

Technical Data - X-S8-F (continue)

Operating Voltage	EIB/KNX bus voltage 21 .. 32 VDC
Power Consumption	approx. 240mW (at 24VDC)
Auxiliary Supply	9 .. 12 VDC / 35mA
Bus Coupler	integrated
Start-up with ETS	ARC_S8.VD2 Product: S8-F
Curcuit Points	EIB-2-pole clamps (red / black)
Protection Class SK01	IP65
Assembly Type Transducer SK01	Assembly with 2 screws finery
Casing Transducer SK01	Plastic grey
Casing Dimensions SK01	72 x 64 x 40 mm (L x W x H)
Article number SK01	308070x1
Protection Class REG	IP20
Casing Dimensions REG	2TE (35 mm)
Article number REG	308070x2
Sensor	LevelJET from ProJET Cable length max. 25 m

7.7 Startup

The KNX Sensor is set up using the ETS (KNX Tool Software) and the applicable application program.
The sensor is delivered unprogrammed.
All functions are programmed and parameterized with ETS.
Please read the ETS instructions.

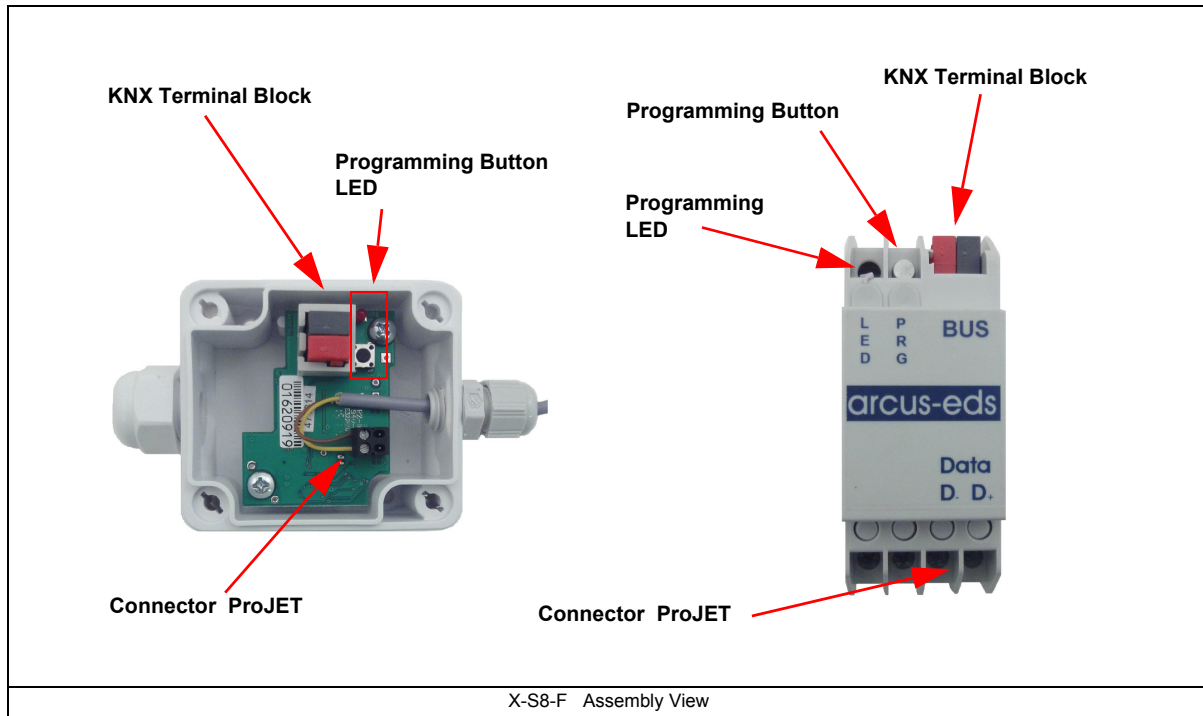

Die Einstellungen des Ultraschallwandlers der Fa. ProJET entnehmen Sie bitte den Herstellerangaben.
<http://projet.de/download.html>

7.8 Assembly

The Sensor **REG-S8-F-xx** is for indoor areas. It fulfills protection class IP20.

The Sensor **SK01-S8-F-xx** is for outdoor and indoor areas. It fulfills protection class IP65.

The sensor is attached to the wall with two screws
The transducer lid is opened by loosening the screws.

The sensor can be installed in the cistern hanging on a chain or attached to its edge with a pipe clamp (plumbing retail).

Installation is possible also under extremely unfavorable conditions, even if there are filters, pipes, floats or cables that (might) disturb the measurement zone of the sensor. The measurement impulse of the sensor must be „guided“, and the easiest way to achieve that is with a pipe. The outside dimension of the sensor is 38.4 mm so that it can easily be inserted into a standard 40 mm PU pipe (available in every hardware store). The pipe should reach to the bottom of the cistern and consist of only one piece. It is important to drill a small vent hole into the pipe close to the sensor to avoid too high or to low pressure.

In order to fulfil IP65 protection class the gasket ring must be carefully placed in the lid.

Be careful not to damage the electronics with tools and cable heads.

Product Page

X-S8-F Ultrasonic Fill Level

In Case of Bus Voltage Recurrence

All changes made using the help key for the KNX/EIB bus are saved if the device has been correctly parameterized. The controller and outputs start with their current values and the ETS parameter settings are saved.

Discharge Program and Reset Sensor

In order to delete the programming (projecting) and to reset the module back to delivery status, it must be switched to zero potential (disconnect the EIB bus coupler).

Press and hold the programming button while reconnecting the EIB bus coupler and wait until the programming LED lights up (approx. 5-10 seconds).

Now you can release the programming button.

The module is ready for renewed projecting.

If you release the programming button too early, repeat the aforementioned procedure.

Imprint

Editor: Arcus-EDS GmbH, Rigaer Str. 88, 10247 Berlin

Responsible for the contents: Hjalmar Hevers, Reinhard Pegelow

Reprinting in part or in whole is only permitted with the prior permission of Arcus-EDS GmbH.

All information is supplied without liability. Technical specifications and prices can be subject to change.

Liability

The choice of the devices and the assessment of their suitability for a specified purpose lie solely in the responsibility of the buyer. Arcus-EDS does not take any liability or warranty for their suitability. Product specifications in catalogues and data sheets do not represent the assurance of certain properties, but derive from experience values and measurements. A liability of Arcus-EDS for damages caused by incorrect operation/projecting or malfunction of devices is excluded. The operator/project developer has to make sure that incorrect operation, planning errors and malfunctions cannot cause subsequent damages.

Safety Regulations

Attention! Installation and mounting must be carried out by a qualified electrician.

The buyer/operator of the facility has to make sure that all relevant safety regulations, issued by VDE, TÜV and the responsible energy suppliers are respected. There is no warranty for defects and damages caused by improper use of the devices or by non-compliance with the operating manuals.

Warranty

We take over guarantees as required by law.

Please contact us if malfunctions occur. In this case, please send the device including a description of the error to the company's address named below.

Manufacturer



Registered Trademarks



The CE trademark is a curb market sign that exclusively directs to authorities and does not include any assurance of product properties.



Registered trademark of the Konnex Association.