

Universal dimmer N 527/02
1 x 230 V AC / 20 - 500 VA
5WG1 527-1AB02

Product and functional description



The universal dimmer N 527/02 is a DIN rail mounted device with N system dimensions. It can dim a group of electrical loads via its output.

Luminaires with incandescent lamps, high-voltage halogen lamps, low-voltage halogen lamps with series-connected, conventional or electronic transformers can be dimmed and switched. If low-voltage halogen lamps should be dimmed, the use of electronic transformers (phase alignment) from Osram is recommended.

It is possible to assign various functions to the output such as switching lamps on and off, dimming up and down or setting them to a specific brightness value i.e. the universal dimmer N 527/02 consists of the device (hardware) and the application program (software).

With the help of ETS (*EIB Tool Software*), the application program can be selected, the specific parameters and addresses are assigned and transferred to the universal dimmer.

Application programs

21 A1 Universal dimmer 906701

- 1-fold universal dimmer for On/Off, dimming, setting values
- Switching possibility on bus voltage recovery
- Dimming range can be set
- Starting value can be parameterised
- Status query or automatic status transmission is possible in the event of a change
- Dimming and value setting from the OFF state possible without switching on
- Possible to dim or jump to the dimming value when setting values
- ON/OFF delay is possible
- Two dimming units are possible

- Fault signal for overload / short circuit
- Fault signal for excess temperature

Connection example

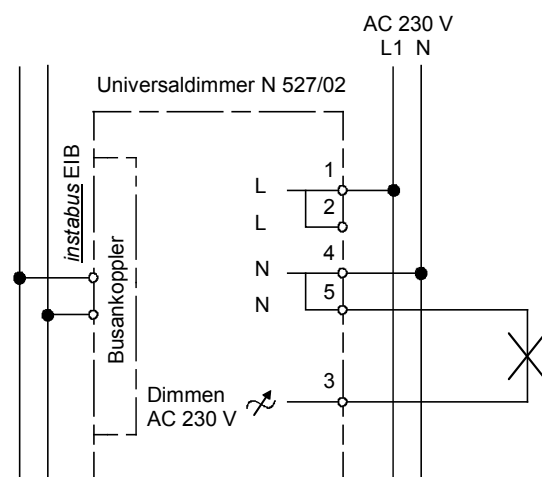

Installation instructions

- The device may only be used for permanent installations in dry interior rooms and for insertion in power distribution boards.



WARNING

- The device may only be installed and commissioned by an authorised electrician.
- Only transformers that are also approved for dimming operation may be used.
- Conventional transformers may only be used if they are VDE approved and have a thermal fuse.
- The no-load operation of conventional, dimmable transformers is neither permitted during commissioning nor during operation, since it may lead to the device being damaged (also when the dimmer is disconnected). Guaranteed by the parallel connection of at least two lamps or transformers. Defective lamps must be replaced immediately.
- The mixed operation of different load types is not permitted! The combination of electronic transformers for dimming with phase alignment and AC 230V incandescent lamps is however allowed.
- The device may only be operated vertically with the ventilation slots at the top and at the bottom. The device must be well ventilated. Heat dissipation must be ensured.

Universal dimmer N 527/02
1 x 230 V AC / 20 - 500 VA

5WG1 527-1AB02

- This device contains a varistor. Due to a disruption of the neutral conductor, overvoltage and conventional transformers running at no load, damage may arise which can lead to the failure of the device at a later date. The connecting cables (external and neutral conductors) must be linked together for dielectric tests.
- For dielectric tests of cables which measure core against core contrary to the current valid norm DIN VDE 0100 T. 610, the device must be disconnected as it may otherwise be destroyed.
- Unassigned sections of DIN rail with inserted data rail must be covered using 5WG1 192-8AA01.
- The prevailing safety and accident regulations must be observed.
- The device must not be opened.
- For planning and construction of electric installations, the relevant guidelines, regulations and standards of the respective country are to be considered.

Technical data

Power supply

Via the bus line and the 230 V mains connection

Mains connection

- Rated voltage: AC 230 - 240V, 50/60 Hz
- Rated current: 2.1 A
- No-load power consumption: approx. 1.4 VA
- No-load leakage loss: approx. 0.7W
- Leakage loss at 500W incandescent lamp load: approx. 4.5W

Safeguard against short circuit / overload

Electronic protection i.e. the universal dimmer switches off in the event of a short circuit / overload. Once the short circuit / overload has been rectified, the universal dimmer can be operated again by Off, a restart or mains interruption at the earliest 2 minutes after being triggered.

Safeguard against excess temperature

Electronic protection i.e. the universal dimmer switches to minimum brightness once the maximum permitted temperature has been exceeded. If the temperature drops below this limit value again, the universal dimmer switches to the current setpoint after 2 minutes.

Dimming behaviour, dimming functions

Can be parameterised, see application program

Behaviour on bus voltage failure

Can be parameterised, see application program

Behaviour on bus voltage recovery

Can be parameterised, see application program

Load output

- Number: 1 output
- Rated voltage: 230 V – 240 V AC, 50/60 Hz
- Rated current: 2.1 A
- Connected load at ambient temperature of 35°C:
 - Incandescent lamps: 500 W
 - High-voltage halogen lamps: 500 W
 - Low-voltage halogen lamps with electronic transformers: 500 W
 - Low-voltage halogen lamps with conventional transformers: 500 VA
- Minimum connected load: 20 W
- Maximum connected load at ambient temperature:

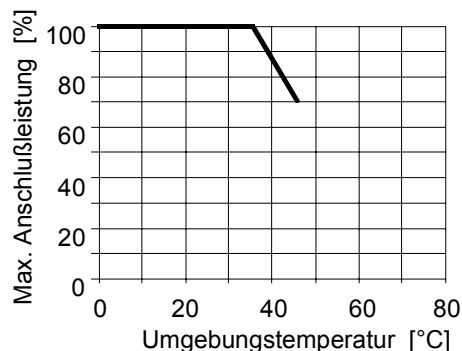

Operating elements

1 learning button:

For toggling between normal mode/addressing mode

Display elements

1 red LED:

For checking the bus voltage and for displaying normal mode/addressing mode

Connections

- Load circuit, mechanical:
 - Insulation strip length 9 ... 10 mm
 - The following conductor cross-sections are permitted:
 - 0.5 ... 2.5 mm² single-core or finely-stranded, 8 mm ultrasonically welded
 - 0.5 ... 2.5 mm² finely-stranded with plug connection, gas-tight crimp connection
 - 0.5 ... 1.5 mm² finely-stranded with connector sleeve

Universal dimmer N 527/02
1 x 230 V AC / 20 - 500 VA

5WG1 527-1AB02

- 1.0 and 1.5 mm² finely-stranded, untreated
- Load circuit, electrical:
 - Finely-stranded conductor, untreated, from 1 mm²: current carrying capacity of max. 6 A
 - Finely-stranded conductor, with plug connector, gas-tight crimp connection, from 1.5 mm²: Current carrying capacity of max. 10 A
 - All other conductors from 1.5 mm²: Current carrying capacity of max. 10 A
- Bus line: Pressure contacts on data rail / bus terminal



WARNING

When looping through the L and N conductor (L and N terminals), it should be noted that the maximum terminal current of 10 A, limited by the permitted printed conductor load, may not be exceeded!

Mechanical data

- Housing: plastic
- Dimensions: DIN rail mounted device with N system dimensions, width 4 modules (1 module = 18 mm)
- Weight: approx. 180 g
- Fire load: approx. 2600
- Installation: Clip-on mounting on DIN rail TH35-7.5 in accordance with DIN 60715:

Electrical safety

- Degree of pollution (in acc. with IEC 664-1): 2
- Type of protection (in acc. with EN 60529): IP 20
- Overvoltage category (in acc. with IEC 664-1): III
- Bus: safety extra-low voltage SELV DC 24 V
- Device complies with EN 50090-2-2 and EN 60669-2-1

EMV requirements

Complies with EN 50090-2-2, EN 60669-2-1

Environmental conditions

- Climatic withstand capability: EN 50090-2-2
- Ambient operating temperature: - 5 ... + 45 °C
- Storage temperature: - 25 ... + 70 °C
- Relative humidity (not condensing): 5 % to 93 %

CE mark

In accordance with the EMC guideline and the low voltage guideline

Markings

KNX / EIB

Location and function of the display and operating elements

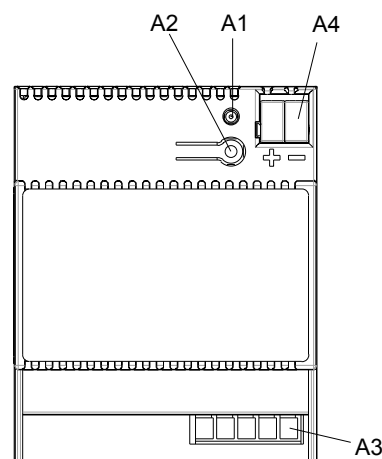

Figure 1: Location of the display and operating elements

- A1 LED for displaying normal mode (LED off) or addressing mode (LED on); it is extinguished automatically after transferring the physical address
- A2 Learning button for toggling between normal mode and addressing mode for transferring the physical address
- A3 Screwless, plug-in terminals for connection of the load circuits
- A4 Bus terminal

Mounting and wiring

General description

The DIN rail mounted device with N-system dimensions (4 modules) can be inserted in N-system distribution boards, either surface- or flush-mounted, and wherever TH35-7.5 DIN rails are available in accordance with DIN 60715. The contact with the bus line is carried out via bus terminals or by snapping the device onto the DIN rail (with data rail inserted). When contact is made via data rail, it must be ensured that the labelling of the newly installed device can be read in the same direction as the remaining devices on the DIN rail. The correct polarity of the device is thereby ensured.

When contact is made via a bus terminal (data rail is not inserted), the contact system to the data rail must be covered by removing the locating pin e.g. using a screwdriver and clipping on the insulating cap supplied, in order to ensure sufficient insulation for the DIN rail.

When installing the universal dimmer N 527/02, the usual connectors can be omitted (this is also the case for other devices on the DIN rail). The bus voltage is routed to the data rail from the bus terminal.

Assembling the DIN rail mounted device (Figure 2)

- Place the device (B1) on the DIN rail (B2) and
- rotate the device downwards until the slide switch audibly clicks into position.

Dismantling the DIN rail mounted device (Figure 2)

- Remove all the connected cables.
- Press the slide switch (C3) down with a screwdriver and
- remove the device (C1) from the DIN rail (C2) with a swivel action.

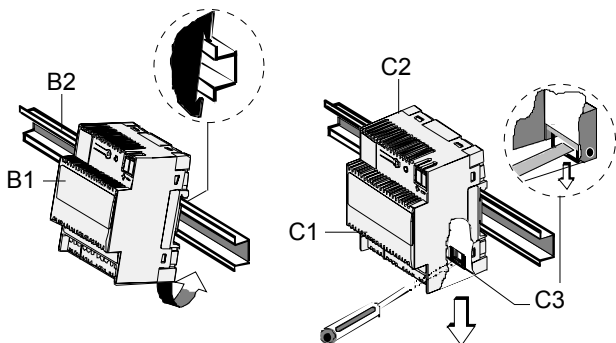

Figure 2: Assembling and dismantling the DIN rail mounted device

Connection to the bus without data rail

If the connection is established via bus connection block (data rail not installed) the data rail connection system has to be covered with the enclosed insulation hood after removing the guiding hood e.g. with a screw driver to guarantee a

sufficient insulation from the DIN rail.

If the Universal dimmer N 527/02 is installed the conventional adapter is not necessary (also for other DIN-rail devices connected to the same data rail). The bus voltage is carried from the bus connection block to the data rail.

Removing the locating pin (Figure 3)

- The locating pin (D3) encloses the contact system (D2) on the rear of the universal dimmer N 527/02 (D1).
- Insert the screwdriver between the DIN rail mounted device (D1) and the locating pin (D3) and remove the pin.

Clipping on the insulating cap (Figure 3)

- Place the insulating cap (D4) on the contact system and press so that it snaps in place.

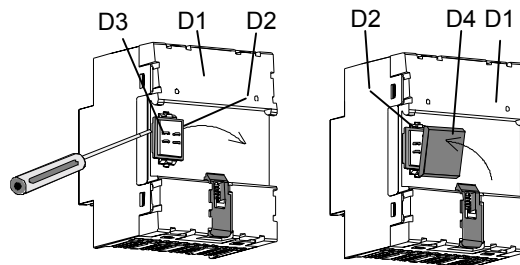

Figure 3: Covering the contact system

Removing the bus terminal (Figure 4)

- The bus terminal is located on the top of the universal dimmer N 527/02 (E2).
- The bus terminal (E1) consists of two sections (E1.1, E1.2), each with four terminal contacts. Care should be taken not to damage the two test sockets (E1.3) either by accidentally connecting them to the bus conductor or with the screwdriver when attempting to remove the bus terminal.
- Carefully insert the screwdriver in the wire entry slot underneath the bus terminal (E1) and pull the bus terminal forwards out of the universal dimmer N 527/02 (E2).

Universal dimmer N 527/02
1 x 230 V AC / 20 - 500 VA

5WG1 527-1AB02

Plugging in the bus terminal (Figure 4)

- Place the bus terminal in the guide slot and
- Press the bus terminal (E1) downwards until it reaches the stop.

Connecting the bus cable (Figure 4)

- The bus terminal (E1) is suitable for single-core conductors with 0.6 ... 0.8 mm Ø.
- Strip approx. 5 mm of insulation from the conductor (E1.4) and plug in the terminal (E1) (red = +, black = -).

Disconnecting the bus cable (Figure 4)

- Remove the bus terminal (E1) and the conductor (E1.4) of the bus cable by rotating them simultaneously backwards and forwards.

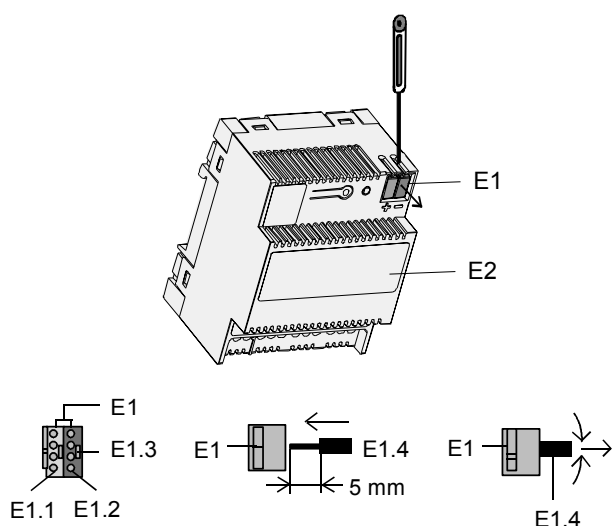

Figure 4: Connecting and disconnecting the bus cable

Connecting load circuits (Figure 5)

- The connections for the load circuits consist of screwless, plug-in terminals (D1).
- Strip approx. 9 ... 10 mm of insulation from the conductor (D1.1) and plug in the terminals (D1).

Cross-sections:

- Load circuit, mechanical:
 Insulation strip length 9 ... 10 mm
 The following conductor cross-sections are permitted:
 - 0.5 ... 2.5 mm² single-core or finely-stranded,
 - 8 mm ultrasonically welded

- 0.5 ... 2.5 mm² finely-stranded with plug connection, gas-tight crimp connection
- 0.5 ... 1.5 mm² finely-stranded with connector sleeve
- 1.0 and 1.5 mm² finely-stranded, untreated
- Load circuit, electrical:
 - Finely-stranded conductor, untreated, from 1 mm²: current carrying capacity of max. 6 A
 - Finely-stranded conductor, with plug connector, gas-tight crimp connection, from 1.5 mm²: Current carrying capacity of max. 10 A
 - All other conductors from 1.5 mm²: Current carrying capacity of max. 10 A

Disconnecting load and control circuits (Figure 5)

- Press the locking device (E1.2) of the terminal (E1) with the screwdriver and
- remove the conductor (E1.1) from the terminal (E1).

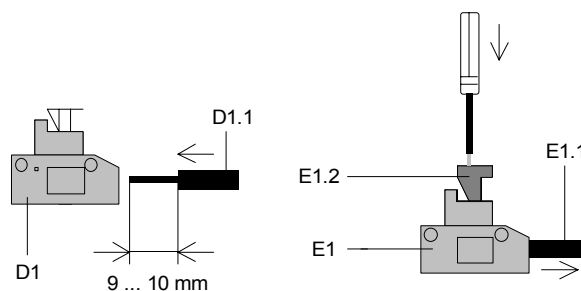
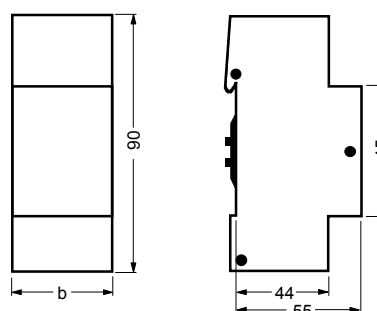

Figure 5: Connecting and disconnecting the cable

Dimension drawing

Dimensions in mm





b = 4 modules

1 module = 18 mm

General Notes

- The operating instructions must be handed over to the client.
- Any faulty devices should be returned to the local Siemens office.
- If you have further questions concerning the product please contact our technical support:

 +49 (0) 180 50 50-222
 +49 (0) 180 50 50-223
 adsupport@siemens.com

Space for notes