

**Operating and mounting instructions**

Product	DELTA profil	DELTA style
<b>Push button 4-fold temperature controller included</b> 	pearl grey 5WG1 231-2AB03 titanium white 5WG1 231-2AB13 anthracite 5WG1 231-2AB23 silver 5WG1 231-2AB73	titanium white 5WG1 231-2EB13 basalt black 5WG1 231-2EB23
	ordered separately from the DELTA ranges	
<b>Frame</b>	cut-out frames	—
<b>Tier frame</b>	—	titanium white 5TG1 328 basalt black 5TG1 368
<b>Bus coupling unit</b>	UP 114	

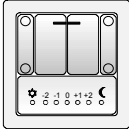
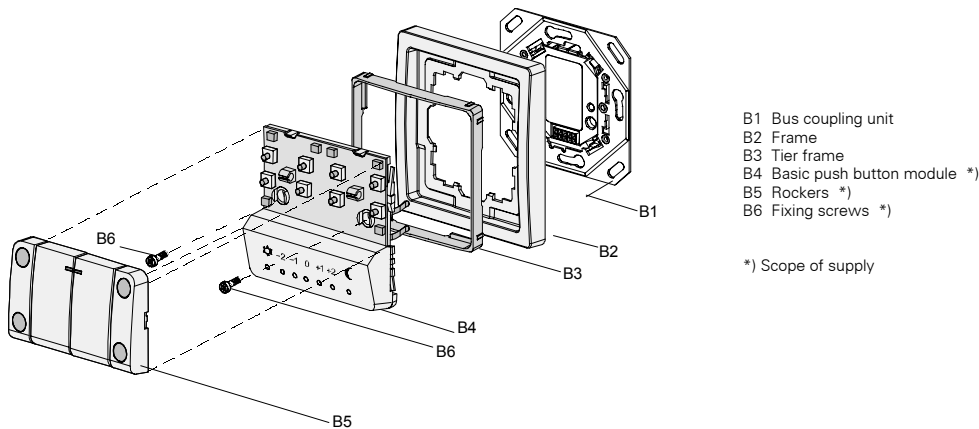

Diagram 1: Mounting the temperature controller UP 231/3

**Product and Functional Description**

The temperature controller UP 231/3 is composed of 2 functional units:  
 The push button 4-fold and the temperature controller.

- **Push button**  
 It has four key rockers with a top and a bottom press point (switching contact). In the idle condition the key rockers occupy the middle position. The middle key rockers (main rockers) are approximately double width designed compared with the outer rockers.  
 Behind the rocker windows of the outer key rockers and of the two middle key rockers there is a red LED in each case.

- **Temperature controller**  
 The functional unit composed of temperature controller and the incorporated temperature sensor is situated beneath the 4-fold key rockers. The set value / mode is displayed via 7 LEDs.

The temperature control via the UP 231/3 is realised by making use of a regulating adaptive algorithm which has been developed only on this purpose. Thus the proportional range and the integration period need not be adjusted to the building and facility conditions by the commissioner as it is the case when PI controllers are employed.

The temperature controller UP 231/3 transmits e.g. commands to actuators for definite switching on / off or to dim fluorescent lamps, to drive up and down venetian blinds and to control valve adjustment drives with an application program via the bus coupling unit.

The temperature controller is slid onto the bus coupling unit UP together with its frame. It requires a bus coupling unit and an appropriate application program to work properly, i.e. the push button (including the bus coupling unit) consists of the devices (hardware) and the application program (software).

The BCU and the relevant frame are not supplied with the device but must be ordered separately. When using DELTA style a tier frame must be employed.

With the ETS (EIB Tool Software) the application program is selected and its parameters and addresses are assigned appropriately.

**Important information**

Operating a temperature controller UP 231/3 requires a bus coupling unit (BCU) UP 114 (version 2.0, R8) or higher.

**Application Programs**

The temperature controller 231/3 works properly only if the application program "temperature controller UP 231/3" is employed.  
 see Siemens product database from version H onward or: <http://www.siemens.de/installationstechnik>

**Technical Specifications**

**Power supply**  
 via bus coupling unit UP 114

- Display elements**
- 4 key rockers, idle in the middle position
  - operating cycles: > 20000

**Display elements**

- 13 LEDs:
- 2 red LEDs behind the rocker windows of the right outer key rocker to indicate the operating modes comfort and standby
  - 2 red LEDs behind the rocker windows of the left outer key rocker always off or as orientation light or to indicate the mode
  - 2 red LEDs behind the rocker windows of the middle key rocker always off or as orientation light or to indicate the mode
  - 5 red LEDs to indicate setpoint adjustment (-2 to +2; setpoint adjustment per key depression can be set in parameter list in the ETS2)
  - 1 green LED to indicate the operating mode night reduction
  - 1 red LED to indicate the operating mode freeze protection

**Temperature detector**

- measuring range: 0 °C to 50 °C
- resolution: 0,1 K
- accuracy between approx. 20 °C to approx. 30 °C: +/- 0,8 °C
- accuracy at the range limits: +/- 1,2 °C
- temperature setpoint adjustment via the left outer key rocker: -2 to +2 in five steps

**Connections**

- 10 pin connector (PEI): for connection to the bus coupling unit UP 114

**Physical specifications**

- housing: plastic
- dimensions (L x W x D):  
 65 x 65 x 15 mm (without spring)  
 65 x 65 x 28 mm (spring included)
- weight: approx. 40 g
- fire load: approx. 1050 kJ ± 10%
- installation: stuck upon the BCU and fastened with two screws

**Electrical safety**

- fouling class (according to IEC 60664-1): 2
- protection (according to EN 60529): IP 20
- protection class (according to IEC 61140): III
- overvoltage class (according to IEC 60664-1): III
- bus: safety extra low voltage SELV DC 24 V
- the device complies with EN 50090-2-2 and EN 60664-1

**Reliability**

rate of failure: 238 fit at 40 °C

**Electromagnetic compatibility**

complies with EN 50081-1, EN 61000-6-2 and EN 50090-2-2

**Environmental specifications**

- climatic conditions: EN 50090-2-2
- ambient temperature operating: - 5 ... + 45 °C
- ambient temperature non-op.: - 25 ... + 70 °C
- relative humidity (non-condensing): 5 % to 93 %

**Certification**

EIB certificate

**CE norm**

complies with the EMC regulations (residential and functional buildings), and low voltage regulations

## Location and Function of the Display and Operator Elements

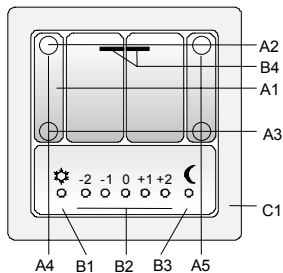

Diagram 2: Location of the display and operator elements

- A1 Four key rockers with top and bottom press points (key contacts)
- A2 Top press points (key contacts)
- A3 Bottom press points (key contacts)
- A4 Key rocker for setpoint adjustment  
Top key contact: +  
Bottom key contact: -
- A5 Key rocker to set the operating modes  
Top key contact: comfort mode



Bottom key contact: standby mode



- B1 LED for displaying the operating mode freeze protection
- B2 LEDs to indicate setpoint adjustment
- B3 LED to indicate the operating mode night reduction
- B4 LEDs for indicating mode or as orientation light
- C1 Frame

## Installation Instructions

- The device may be used for permanent interior installations in dry locations within box mounts (with bus coupling unit UP 114).
- Direct warming up, e.g. caused by the radiant heat of the sun beams, the output heat of radiators, etc. should be avoided.
- It should be avoided that there is a draught in the flush-mounted box, e.g. due to cable vents which have not been made tight.

## WARNING

- The device must be mounted and commissioned by an authorised electrician.
- The device must not be mounted in box mounts together with 230 V devices.
- The device may be mounted to switch and socket combination box mounts provided VDE-certified devices are used exclusively.
- The prevailing safety rules must be heeded.
- A device suspected faulty should be returned to the local Siemens office

## Mounting

### General description

The temperature controller UP 231/3 is slid onto the bus coupling unit together with its frames.

The flush-mounted bus coupling unit (B1) is connected and fixed in position in the flush-type box (see installation instructions for the flush-mounted bus coupling unit).

### Mounting sequence

- Place the push button module (B4) with the relevant frame (B2/B3) on the flush-mounted bus coupler (C1) and press the one strongly upon the other (diagram 3).

#### Using fixing screws:

- If the fixing screws (B6) are used first of all the rockers (B5) have to be lifted out altogether. This can be achieved by inserting the screwdriver between the frames in the recess (B8) and applying leverage (diagram 4).

Important: The push button module (B4) and the rockers (B5) together with the frame (B2) must be held down / pressed down.

- Screw down the fixing screws (B6).
- The rockers (B5) have to be orientated properly and clicked upon the mounting rack (B7).

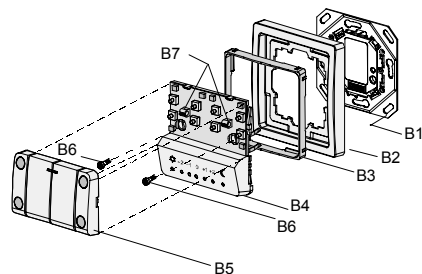

Diagram 3: Mounting sequence

## Drawing representing the installation

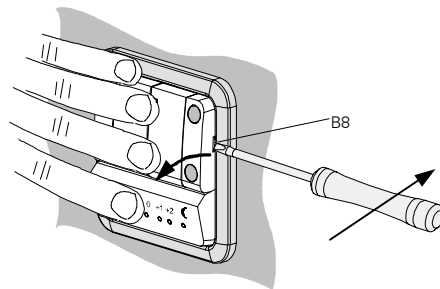

Diagram 4: Lifting out the key rockers

## Dismantling

### Without fixing screws

- Remove the temperature controller UP 231/3 (B4) completely together with the frame (B2/B3) from the flush-mounted bus coupler (B1):  
a) with the mere hand  
b) with a screwdriver beneath the frame / wall

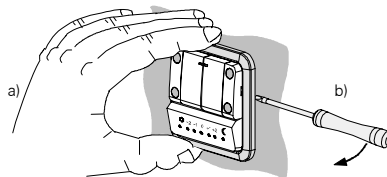

Diagram 5: Dismantling

### With fixing screws

- Insert a screwdriver into the recess (B8) between the frame (B2/B3) and remove the rockers (B5) by applying leverage.
- Screw out the fixing screws (B6)
- The rockers (B5) have to be orientated properly and clicked upon the mounting rack (B7).
- Remove the whole push button module (B4) as described at „ Without fixing screws “.